

MEDIUM VOLTAGE FAST-SWITCHING NPN POWER TRANSISTOR

PRELIMINARY DATA

- SGS-THOMSON PREFERRED SALESTYPE
- MEDIUM VOLTAGE CAPABILITY
- LOW SPREAD OF DYNAMIC PARAMETERS
- MINIMUM LOT-TO-LOT SPREAD FOR RELIABLE OPERATION
- VERY HIGH SWITCHING SPEED
- FULLY CHARACTERISED AT 125°C
- THROUGH-HOLE IPAK (TO-251) POWER PACKAGE IN TUBE (SUFFIX "-1")

APPLICATIONS

- ELECTRONIC BALLASTS FOR FLUORESCENT LIGHTING
- FLYBACK AND FORWARD SINGLE TRANSISTOR LOW POWER CONVERTERS

DESCRIPTION

The BULD26 is manufactured using medium voltage Multi Epitaxial Planar technology for high switching speeds and medium voltage capability. It uses a Cellular Emitter structure with planar edge termination to enhance switching speeds while maintaining a wide RBSOA.

The BUL series is designed for use in lighting applications and low cost switch-mode power supplies.

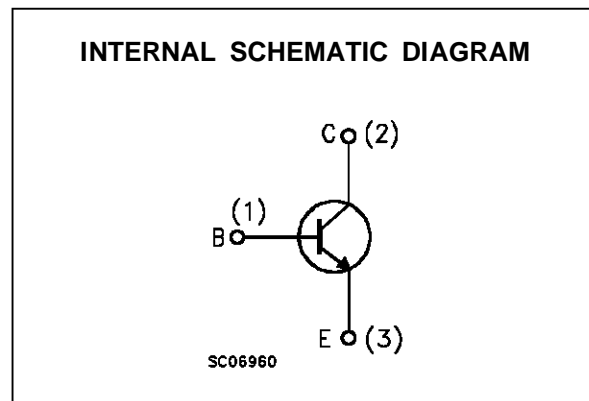
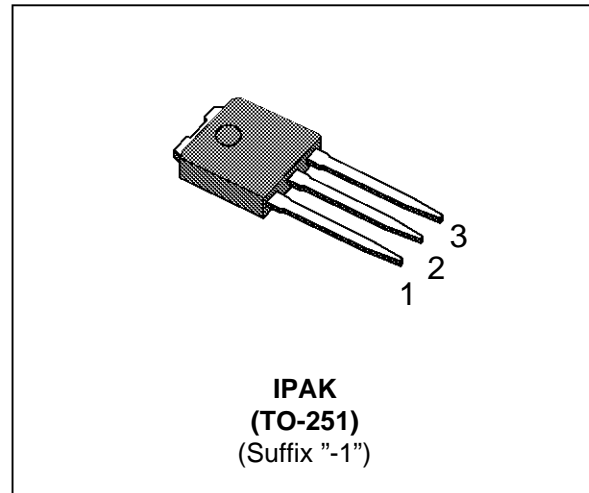

ABSOLUTE MAXIMUM RATINGS

Symbol	Parameter	Value	Unit
V_{CES}	Collector-Emitter Voltage ($V_{BE} = 0V$)	600	V
V_{CEO}	Collector-Emitter Voltage ($I_B = 0$)	300	V
V_{EBO}	Emitter-Base Voltage ($I_C = 0$)	10	V
I_C	Collector Current	4	A
I_{CM}	Collector Peak Current ($t_p < 5$ ms)	8	A
I_B	Base Current	2	A
I_{BM}	Base Peak Current ($t_p < 5$ ms)	4	A
P_{tot}	Total Dissipation at $T_c = 25$ °C	20	W
T_{stg}	Storage Temperature	-65 to 150	°C
T_j	Max. Operating Junction Temperature	150	°C

BULD26

THERMAL DATA

$R_{thj-case}$	Thermal Resistance Junction-case	Max	6.25	$^{\circ}C/W$
$R_{thj-amb}$	Thermal Resistance Junction-ambient	Max	100	$^{\circ}C/W$

ELECTRICAL CHARACTERISTICS ($T_{case} = 25^{\circ}C$ unless otherwise specified)

Symbol	Parameter	Test Conditions	Min.	Typ.	Max.	Unit
I_{CES}	Collector Cut-off Current ($V_{BE} = 0$)	$V_{CE} = 600 V$			100	μA
		$V_{CE} = 600 V \quad T_j = 125^{\circ}C$			500	μA
I_{CEO}	Collector Cut-off Current ($I_B = 0$)	$V_{CE} = 300 V$			250	μA
$V_{CEO(sus)}$	Collector-Emitter Sustaining Voltage	$I_C = 100 mA \quad L = 25 mH$	300			V
V_{EBO}	Emitter-Base Voltage	$I_E = 10 mA$	10			V
$V_{CE(sat)*}$	Collector-Emitter Saturation Voltage	$I_C = 1 A \quad I_B = 0.2 A$			0.5	V
		$I_C = 2 A \quad I_B = 0.4 A$			0.7	V
		$I_C = 3 A \quad I_B = 0.6 A$			1	V
$V_{BE(sat)*}$	Base-Emitter Saturation Voltage	$I_C = 1 A \quad I_B = 0.2 A$			1.1	V
		$I_C = 2 A \quad I_B = 0.4 A$			1.2	V
		$I_C = 3 A \quad I_B = 0.6 A$			1.3	V
h_{FE*}	DC Current Gain	$I_C = 10 mA \quad V_{CE} = 5 V$	10			
		$I_C = 1 A \quad V_{CE} = 3 V$	15		45	
t_s t_f	INDUCTIVE LOAD Storage Time Fall Time	$I_C = 3 A \quad I_{B1} = 0.6 A$		0.8	1.5	μs
		$V_{BE(off)} = -5 V \quad R_{BB} = 0 \Omega$ $V_{CL} = 250 V \quad L = 200 \mu H$		65	130	ns
t_s t_f	INDUCTIVE LOAD Storage Time Fall Time	$I_C = 3 A \quad I_{B1} = 0.6 A$		1.1		μs
		$V_{BE(off)} = -5 V \quad R_{BB} = 0 \Omega$ $V_{CL} = 250 V \quad L = 200 \mu H$ $T_j = 125^{\circ}C$		120		ns

* Pulsed: Pulse duration = 300 μs , duty cycle 1.5 %

Safe Operating Areas

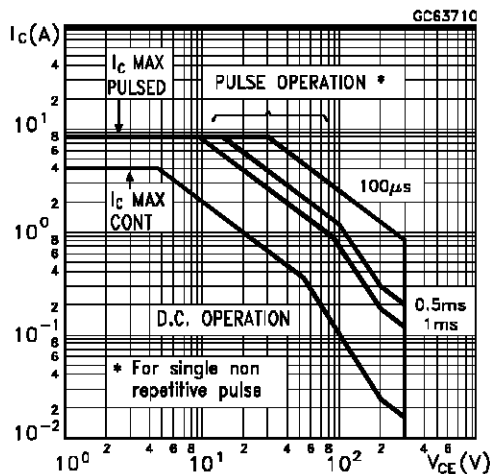

Derating Curves

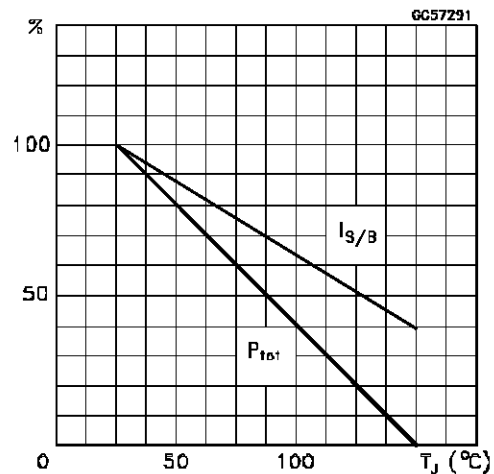

DC Current Gain

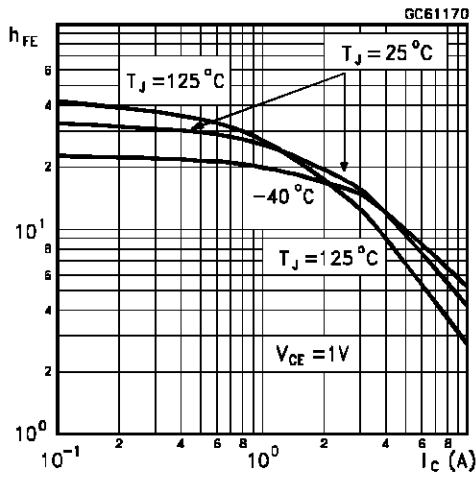

DC Current Gain

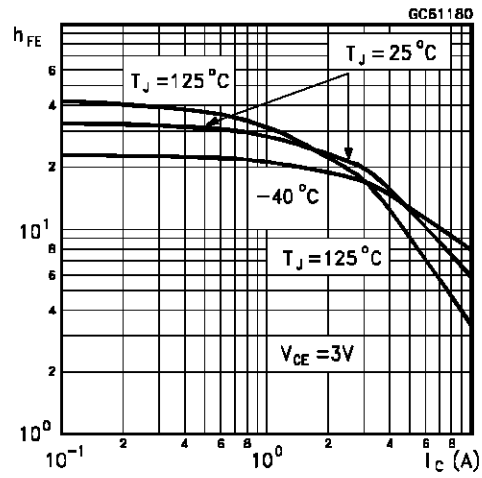

Collector-Emitter Saturation Voltage

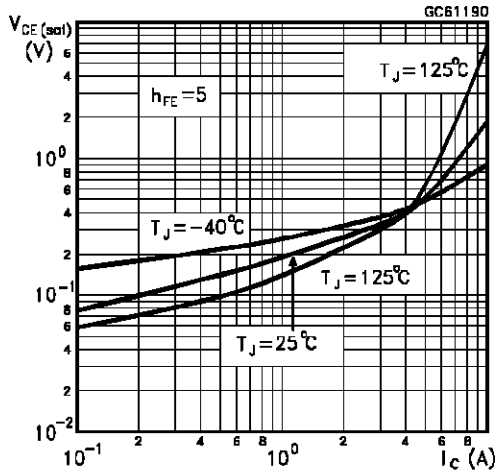

Base-Emitter Saturation Voltage

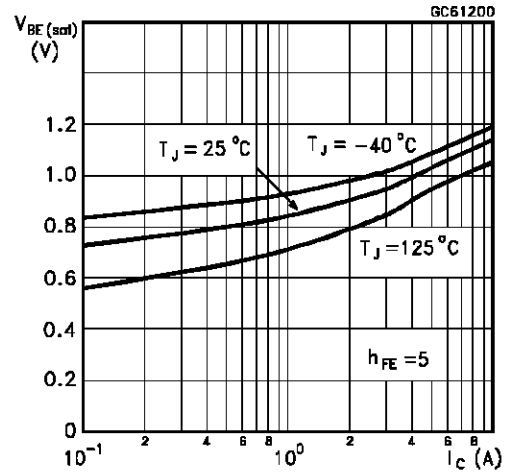

Inductive Fall Time

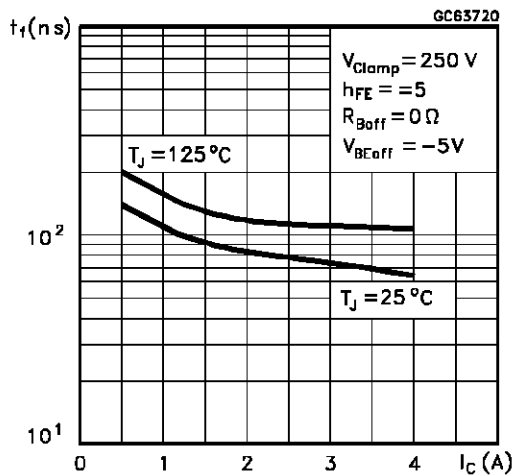

Inductive Storage Time

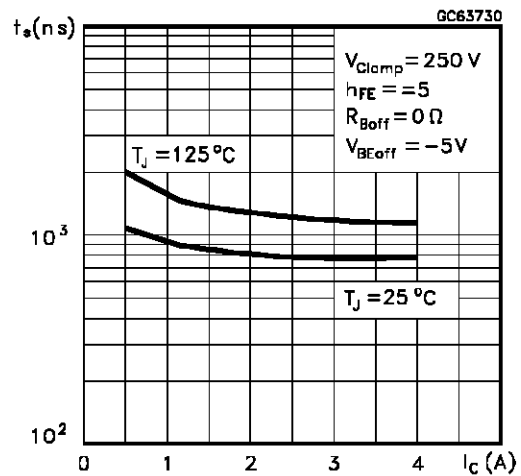

Reverse Biased SOA

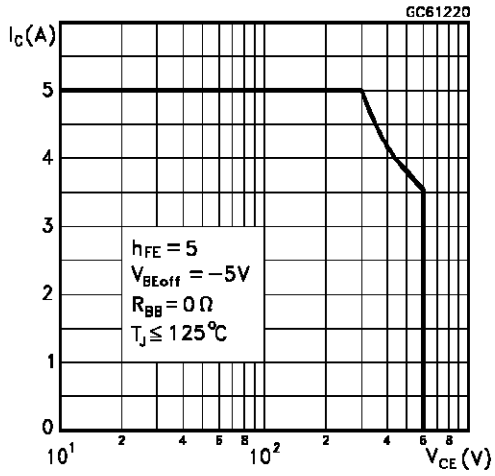

RBSOA and Inductive Load Switching Test Circuit

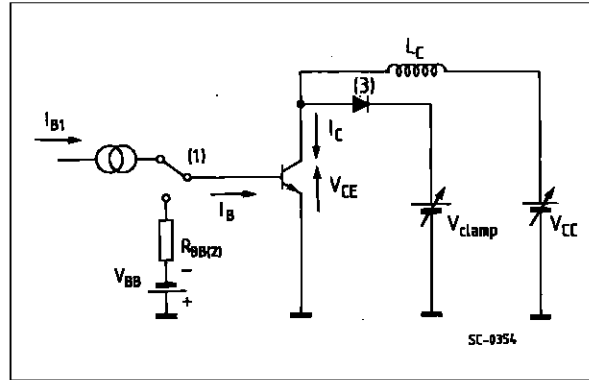

- (1) Fast electronic switch
- (2) Non-inductive Resistor
- (3) Fast recovery rectifier

TO-251 (IPAK) MECHANICAL DATA

DIM.	mm			inch		
	MIN.	TYP.	MAX.	MIN.	TYP.	MAX.
A	2.2		2.4	0.086		0.094
A1	0.9		1.1	0.035		0.043
A3	0.7		1.3	0.027		0.051
B	0.64		0.9	0.025		0.031
B2	5.2		5.4	0.204		0.212
B3			0.85			0.033
B5		0.3			0.012	
B6			0.95			0.037
C	0.45		0.6	0.017		0.023
C2	0.48		0.6	0.019		0.023
D	6		6.2	0.236		0.244
E	6.4		6.6	0.252		0.260
G	4.4		4.6	0.173		0.181
H	15.9		16.3	0.626		0.641
L	9		9.4	0.354		0.370
L1	0.8		1.2	0.031		0.047
L2		0.8	1		0.031	0.039

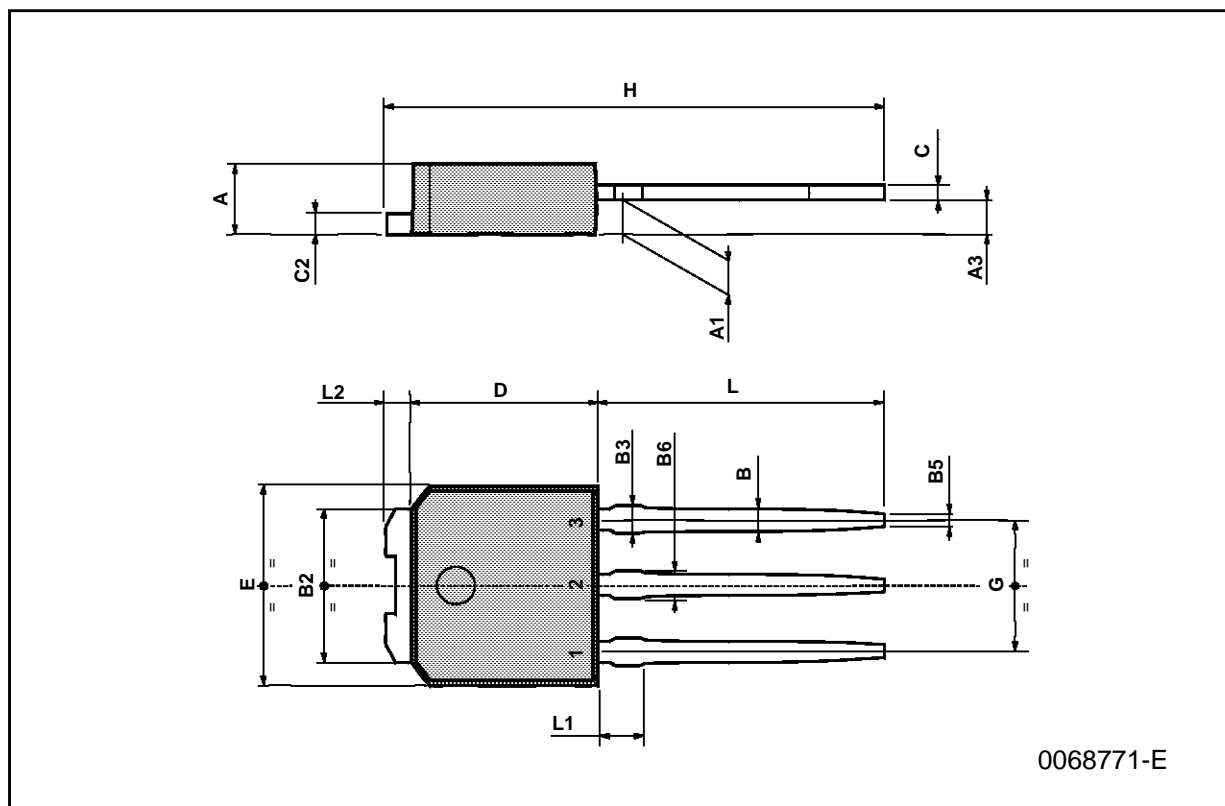

Information furnished is believed to be accurate and reliable. However, SGS-THOMSON Microelectronics assumes no responsibility for the consequences of use of such information nor for any infringement of patents or other rights of third parties which may result from its use. No license is granted by implication or otherwise under any patent or patent rights of SGS-THOMSON Microelectronics. Specifications mentioned in this publication are subject to change without notice. This publication supersedes and replaces all information previously supplied. SGS-THOMSON Microelectronics products are not authorized for use as critical components in life support devices or systems without express written approval of SGS-THOMSON Microelectronics.

© 1994 SGS-THOMSON Microelectronics - All Rights Reserved

SGS-THOMSON Microelectronics GROUP OF COMPANIES
Australia - Brazil - France - Germany - Hong Kong - Italy - Japan - Korea - Malaysia - Malta - Morocco - The Netherlands -
Singapore - Spain - Sweden - Switzerland - Taiwan - Thailand - United Kingdom - U.S.A